

Glass Flush Half-Dome 20"

ALLIED MAKER

WAC-029



Glass Flush Half-Dome 20"



ALLIED MAKER

WAC-029

MATERIALS

Brass, Glass, Wood

GLASS FINISHES

Clear, Frosted, Matte White, Opal, Smoked

WOOD FINISHES

Available in All Standard Wood Finishes

MOUNTING HARDWARE DIAGRAM

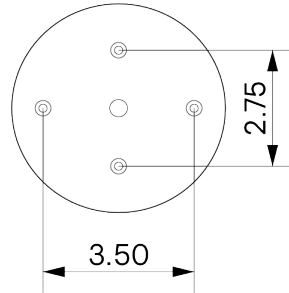
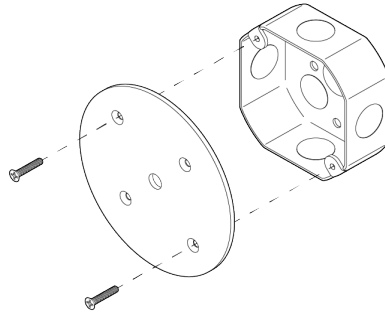

MOUNTING

Universal

WEIGHT

13.5 lb

LAMPING

E26 or E27 Screw Base. Type A Lamps

BULB INCLUDED (120V USA)

Cree 75W Bulb

BULB INCLUDED (240V EU)

Emery Allen 8.5W 240V Bulb

LAMP QUANTITY

1

BRIGHTNESS

1600 Lumens

MAX WATTAGE

20W

DIMMING

Universal

DIMENSIONAL DRAWING

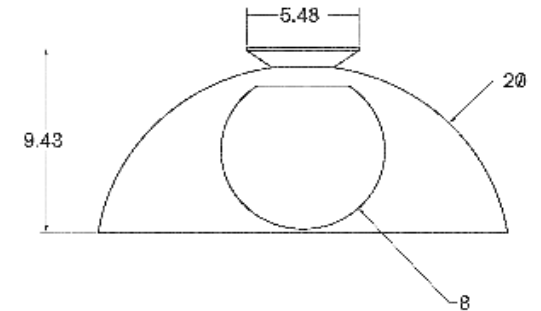

CERTIFICATIONS

CE, Damp Locations, Outdoor and Wet Locations, UL and cUL Certified

